

APPENDIX 46C

UNITIZATION PROCEDURES FOR BOXED AMMUNITION AND COMPONENTS ON 4-WAY ENTRY PALLETS

CARTRIDGE, 165MM, PACKED 1 PER WOODEN BOX,
UNITIZED 25 BOXES PER 40" X 48" PALLET;
APPROX BOX SIZE $34\frac{13}{16}$ L X $8\frac{3}{4}$ W X $9\frac{13}{16}$ H

PALLET UNIT DATA						
ITEMS INCLUDED		HAZARD CLASSIFICATION ^①				WEIGHT (LBS)
NSN	DODIC	DOT CLASS	CG CLASS	QD CLASS	COMP GROUP	
1320- 00-555-5126 00-926-4072	D570 D590	A B	IV II-B	1.1 (08) 1.2	D C	2,416 2,416

NOTICE: THIS APPENDIX CANNOT STAND ALONE BUT MUST
BE USED IN CONJUNCTION WITH THE BASIC UNITIZATION
PROCEDURES DRAWING 19-48-4116-20PA1002.

① HAZARD CLASSIFICATION DATA CONTAINED IN THE ABOVE CHART IS FOR GUIDANCE AND INFORMATIONAL PURPOSES ONLY. VERIFICATION OF THE SPECIFIED DATA SHOULD BE MADE BY CONSULTING THE MOST RECENT JOINT HAZARD CLASSIFICATION SYSTEM LISTING OR OTHER APPROVED LISTING (S).

THIS DRAWING SUPERSEDES DRAWING 19-48-4138/27-20PA1000,
DATED FEBRUARY 1981, AND REVISION 1 THERETO, DATED
NOVEMBER 1983.

DO NOT SCALE

REVISIONS				DRAFTSMAN <i>dh</i>	PROJ ENG <i>WRF</i>
				CHECKER <i>GLS</i>	LOG ENGRG OFFICE <i>WRF</i>
APPROVED, U.S. ARMY ARMAMENT, MUNITIONS AND CHEMICAL COMMAND					
<i>Martin</i> <i>WRF</i>					
APPROVED BY ORDER OF COMMANDING GENERAL, U.S. ARMY MATERIEL COMMAND (AMC)					
<i>John J. Spady</i>					
U.S. ARMY AMC DRAWING					
JUNE 1986					
CLASS	DIVISION	DRAWING	FILE		
19	48	4116/46C	20PA 1002		

TIEDOWN STRAP, 3/4" X .035" OR .031" X 14'-3" LONG STEEL STRAPPING (5 REQD). SEE GENERAL NOTE "D" AT RIGHT.

TOP CLEATS ON THE BOXES IN THE OUTSIDE STACKS WILL BE TURNED INWARD, EXCEPT AS OTHERWISE SPECIFIED IN MIL-STD-129.

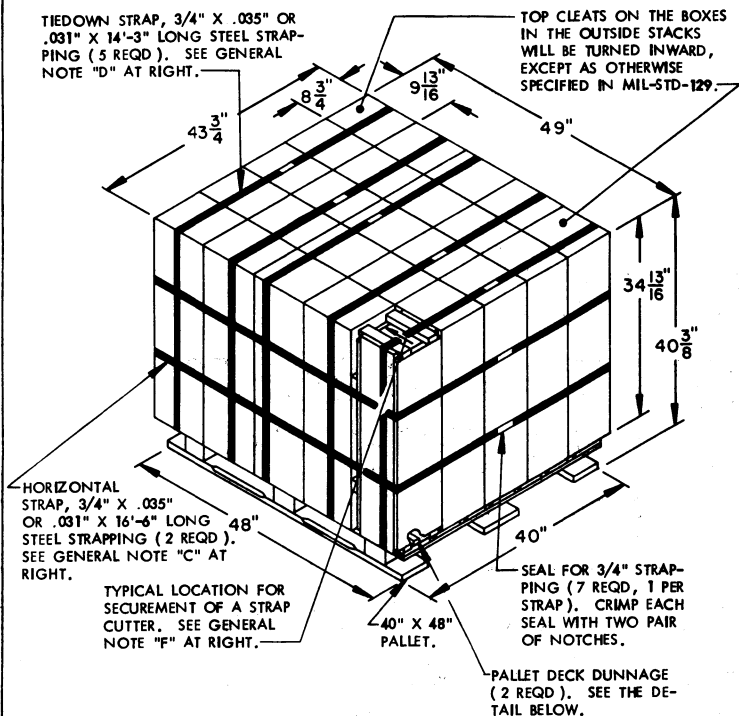

PALLET UNIT

(SEE GENERAL NOTE "B" AT RIGHT)

25 BOXES OF 165MM CARTRIDGES (1 PER BOX) @ 93 LBS ----- 2,325 LBS (APPROX)
 DUNNAGE ----- 11 LBS
 PALLET ----- 80 LBS

TOTAL WEIGHT ----- 2,416 LBS (APPROX)
 CUBE ----- 50.1 CU FT (APPROX)

GENERAL NOTES

- A. THIS APPENDIX CANNOT STAND ALONE BUT MUST BE USED IN CONJUNCTION WITH THE BASIC UNITIZATION PROCEDURES DRAWING 19-48-4116-20PA1002. TO PRODUCE AN APPROVED UNIT LOAD, ALL PERTINENT PROCEDURES, SPECIFICATIONS AND CRITERIA SET FORTH WITHIN THE BASIC DRAWING WILL APPLY TO THE PROCEDURES DELINEATED IN THIS APPENDIX. ANY EXCEPTIONS TO THE BASIC PROCEDURES ARE SPECIFIED IN THIS APPENDIX.
- B. DIMENSIONS, CUBE AND WEIGHT OF A PALLET UNIT WILL VARY SLIGHTLY DEPENDING UPON THE ACTUAL DIMENSIONS OF THE BOXES AND THE WEIGHT OF THE SPECIFIC ITEM BEING UNITIZED.
- C. INSTALL EACH HORIZONTAL STRAP TO ENCIRCLE THE LAYER OF BOXES ON THE PALLET. HORIZONTAL STRAPS MUST BE TENSIONED AND SEALED PRIOR TO APPLICATION OF TIEDOWN STRAPS.
- D. INSTALL EACH TIEDOWN STRAP TO PASS UNDER THE DECK/STRINGER BOARDS OF THE PALLET AND TO BE LOCATED AS SHOWN. TIEDOWN STRAPS WILL NOT BE APPLIED UNTIL THE HORIZONTAL STRAPS HAVE BEEN TENSIONED AND SEALED.
- E. THE FOLLOWING AMC (DARCOM) DRAWINGS ARE APPLICABLE FOR OUTLOADING AND STORAGE OF THE ITEMS COVERED BY THIS APPENDIX.
 CARLOADING ----- DRAWING 19-48-4115-SPA1002
 TRUCKLOADING ----- DRAWING 19-48-4117-11PA1003
 STORAGE ----- DRAWING 19-48-4118-1-2-3-4-14-22PA1002
- F. FOR METHOD OF SECURING A STRAP CUTTER TO THE PALLET UNIT, SEE DARCOM DRAWING 19-48-4127-20P1000.
- G. IF ITEMS COVERED HEREIN ARE UNITIZED PRIOR TO ISSUANCE OF THIS APPENDIX, THE BOXES NEED NOT BE REUNITIZED SOLELY TO CONFORM TO THIS APPENDIX.
- H. THE UNITIZATION PROCEDURES DEPICTED HEREIN MAY ALSO BE USED FOR UNITIZING 165MM CARTRIDGES WHEN IDENTIFIED BY DIFFERENT NATIONAL STOCK NUMBERS (NSN) THAN WHAT IS SHOWN ON THE TITLE PAGE, PROVIDED THE BOX PACK DOES NOT VARY FROM WHAT IS DELINEATED HEREIN. THE EXPLOSIVE CLASSIFICATION OF OTHER ITEMS MAY BE DIFFERENT THAN WHAT IS SHOWN.
- J. IF THERE IS A NEED TO USE FILLER ASSEMBLIES AND AT LEAST TWO PALLET UNITS ARE BEING CONSTRUCTED, NOT MORE THAN TWENTY-ONE FILLERS WILL BE INSTALLED IN ONE PALLET UNIT. ADDITIONAL FILLERS CAN BE INSTALLED IN A SECOND PALLET UNIT WHEN THE QUANTITY OF TWENTY-ONE FILLERS IS INSUFFICIENT TO SATISFY THE TOTAL REDUCTION NEEDED. USING TWO PALLET UNITS TO SATISFY THE PALLETIZATION CRITERIA APPLICABLE TO LESS-THAN-FULL PALLET UNITS IS AN EXCEPTION TO THE BASIC PROCEDURES. HOWEVER, THIS EXCEPTION IS NECESSARY FOR THE AMMUNITION PACK COVERED IN THIS APPENDIX TO MOST EFFECTIVELY GET AN ACCEPTABLE, COMPACT AND SOUND PALLET UNIT.

BILL OF MATERIAL

LUMBER	LINEAR FEET	BOARD FEET
1" X 2"	8.00	1.33
NAILS	NO. REQD	POUNDS
4d (1-1/2")	8	NIL
PALLET, 40" X 48" ----- 1 REQD ----- 80 LBS		
STEEL STRAPPING, 3/4" ----- 104.25' REQD ----- 7.45 LBS		
SEAL FOR 3/4" STRAPPING ----- 7 REQD ----- NIL		

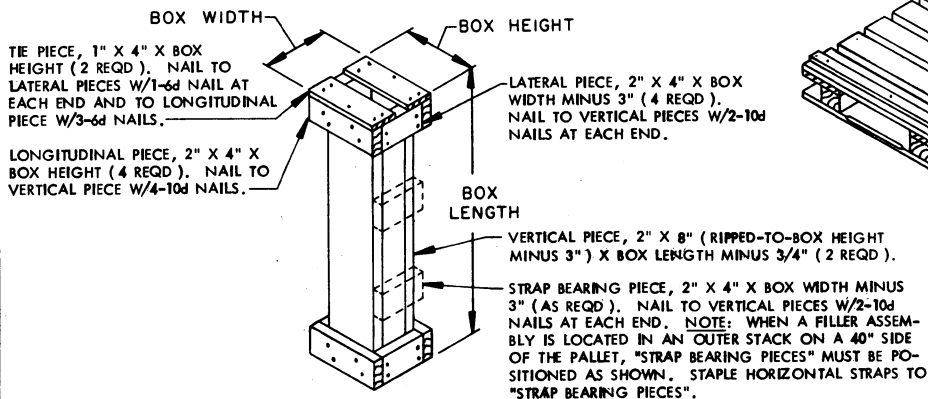

FILLER ASSEMBLY

(FOR MINUS ONE BOX)

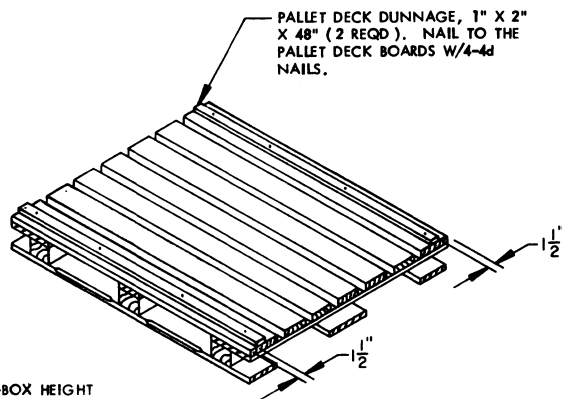

PALLET DUNNAGE LOCATION